



DEPARTMENT OF
ENVIRONMENTAL PROGRAMS

Worcester County

GOVERNMENT CENTER
ONE WEST MARKET STREET, ROOM 1306
SNOW HILL, MARYLAND 21863
TEL: 410.632.1220 / FAX: 410.632.2012

LAND PRESERVATION PROGRAM
STORMWATER MANAGEMENT
SEDIMENT AND EROSION CONTROL
SHORELINE CONSTRUCTION
AGRICULTURAL PRESERVATION
ADVISORY BOARD

WELL & SEPTIC
WATER & SEWER PLANNING
PLUMBING & GAS
CRITICAL AREAS/FORESTRY
COMMUNITY HYGIENE

April 16, 2026

This notification is to advise you that the Department has received and is presently reviewing the following request for a shoreline construction project:

Gus Durso - Request No. 2026-023 – Request to remove existing dock and install new 5'x27' pier. Request to install one four piling boat lift with associated pilings. Max channelward extension 27'. This project is located at 49 Moonshell Drive, Berlin, also known as Tax Map 16, Parcel 41, Lot 165. Third Tax District of Worcester County, Maryland.

The Department in considering this application will make specific findings of fact with regard to the environmental impact, navigational impact, recreational potential, commercial benefit to Worcester County, impact of the proposed construction upon the surrounding neighborhood and upon property values therein, and any other pertinent issues. Approval from the Department does not guarantee approval from any other applicable regulatory agencies.

If you have an interest which may be adversely affected by the issuance of this permit, you are requested to notify this Department in writing within fifteen (15) calendar days which will end on May 1, 2026.

Sincerely,

Brandy Whitlock
Natural Resources Specialist II

cc: Interested Parties
David Bradford, Deputy Director
File



WORCESTER COUNTY
SHORELINE CONSTRUCTION
APPLICATION

Request No.: 2026-023
Submission Date: 4-16-26

X Major Construction (\$300.00)
Minor Construction (\$150.00)

Written Description of Proposed Improvement (include channelward distance):

Remove Existing Dock, Install 5' x 27' Pier , Install (1) 4 Piling Boat Lift w/ Associate Pilings, Max Chnl. 27'

Property Description:

Map: 0016 Parcel: 0041 Lot: 165 Section: 4 Block: Tax District: 03
Street Address: 49 Moonshell Dr., Ocean Pines, MD 21811
Subdivision:
Dwelling on lot: Dwelling under construction: Vacant: Commercial:

Owner: Gus Durso Phone No. 678-602-5144
Mailing Address: 49 Moonshell Dr., Ocean Pines, MD 21811
E-Mail Address: gusd1026@gmail.com

Contractor: Ocean City Boat Lifts & Marine Construction Inc Phone No.: 410-352-5095
Mailing Address: P.O. Box 135, Bishopville, MD 21813
E-Mail Address: oceancitylifts.kayla@aol.com

Recorded Adjacent Property Owner: M & J Loveless Family Trust

Property Address: 17625 Buehler Rd., Olney MD, 20832
Tax Map: 0016 Parcel: 0041 Lot: 166 Section: 4 Block:

Recorded Adjacent Property Owner: Mr. & Mrs. Abernethy

Property Address: 95 Bell St., North Brookfield, MA 01535
Tax Map: 0016 Parcel: 0041 Lot: 164 Section: 4 Block:

As the applicant, I attest that the information presented on this application, site plan and any written documentation attached hereto is known to be accurate. I understand that the proposed shoreline improvement will be constructed to meet or exceed minimum design standards adopted by the Department. Any deviation from these standards will require construction plans sealed by an engineer registered in the State of Maryland. I acknowledge that any falsification of information presented may result in revocation of this approval and of the subsequent Shoreline Construction Permit.

Gus Durso 3/14/26
Owner/Applicant's Signature Date

DEPT. USE ONLY:

Notification Distribution Date: 4-16-26 Public Comment Deadline: 5-1-26 15 calendar days
Department Approval Date: Expiration:

North Arrow

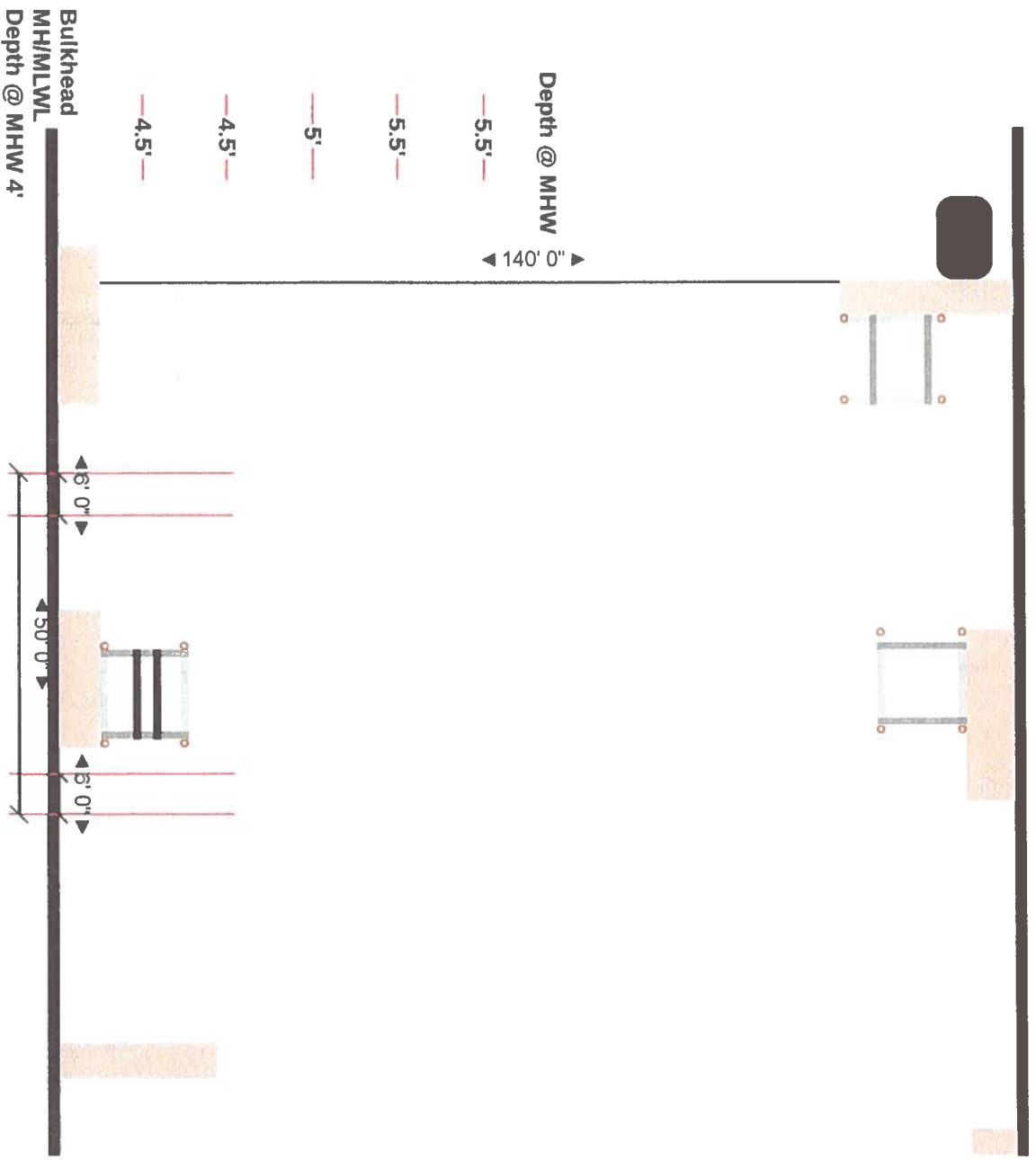

| | | | | | | | | | | |
|----------------|---|-----------------|----------|-------------|-----------|-------------|---------------|--------|-----------------------------|--|
| Site: | 49 Moonshell Drive, Ocean Pines, MD 21811 | Property Owner: | G. Durso | Project ID: | 25-243 | Plan: | Existing | Notes: | -No known SAV -Mar Chnl. | Ocean City Boat Lifts (410) 352-5095 oceancitylifts.kaylabeal.com 12010 Industrial Park Rd., Unit 11, Bishopville, MD 21813 |
| Scope of Work: | Remove existing dock & boat lift, install 5' x 27' pier, install 4 piling boat lift w/ associate piling | Scale: | 1"=15' | Date: | 3/14/2025 | Contractor: | OC Boat Lifts | | | |

North Arrow

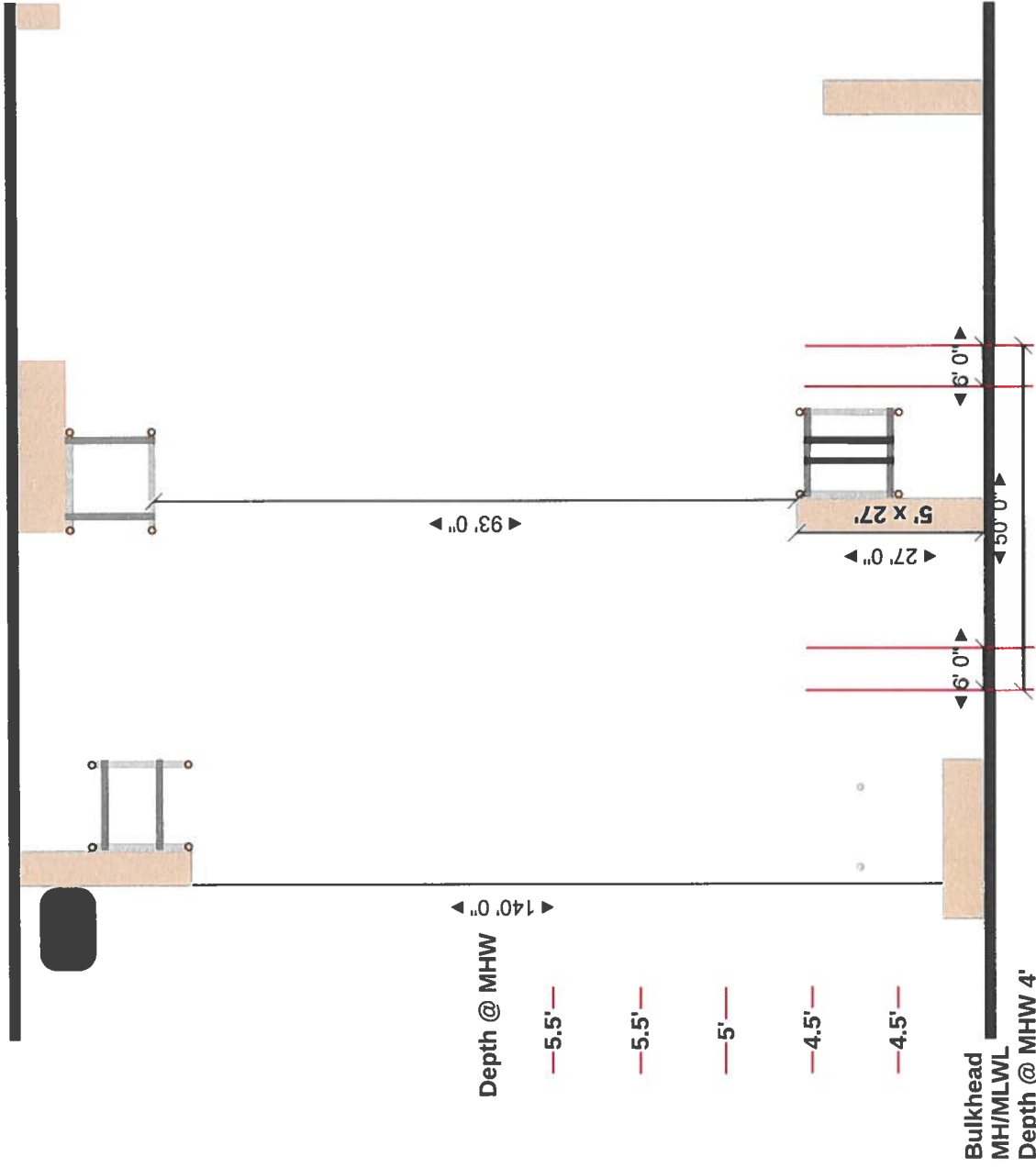

| | | | | | | | | | |
|----------------|---|-----------------|----------|-------------|-----------|-------------|---------------|---------------------------------|--|
| Site: | 49 Moonshell Drive, Ocean Pines, MD 21811 | Property Owner: | G. Durso | Project ID: | 25-243 | Plan: | Proposed | Notes: | Ocean City Boat Lifts (410) 352-5095 oceancitylifts.kayla@aol.com 12010 Industrial Park Rd., Unit 11, Bishopville, MD 21813 |
| Scope of Work: | Remove existing dock & boat lift, Install 5' x 27' pier, Install 4 piling boat lift w/ associate piling | Scale: | 1"=15' | Date: | 3/14/2025 | Contractor: | OC Boat Lifts | -No known SAV -Max Chnl. 27' | |

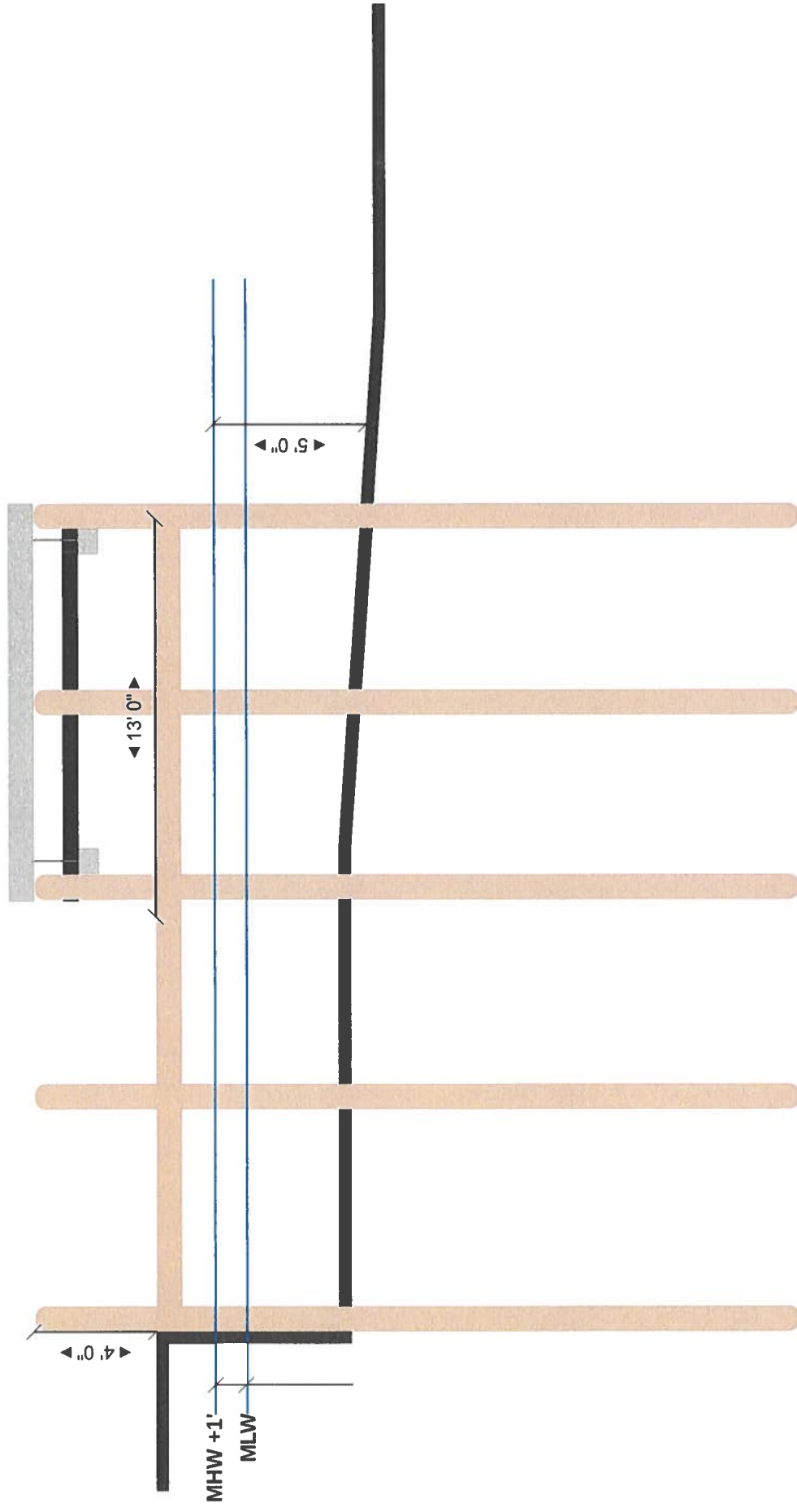

| | | | | |
|---|-------------------------------------|-------------------------------|--------------------------------------|--|
| <p>Site: 49 Moonshell Drive, Ocean Pines, MD 21811</p> | <p>Property Owner: G. Durso</p> | <p>Project ID: 25-243</p> | <p>Plan: Cross Section</p> | <p>Notes: -No known SAV -Max Chnl.</p> |
| <p>Scope Of Work: Remove existing dock & boat lift, Install 5' x 27' pier, Install 4 piling boat lift w/ associate piling</p> | <p>Scale: 1"=5'</p> | <p>Date: 3/14/2025</p> | <p>Contractor: OC Boat Lifts</p> | <p>Ocean City Boat Lifts (410) 352-5095 oceancitylifts.kayla@aol.com 12010 Industrial Park Rd., Unit 11, Bishopville, MD 21813</p> |

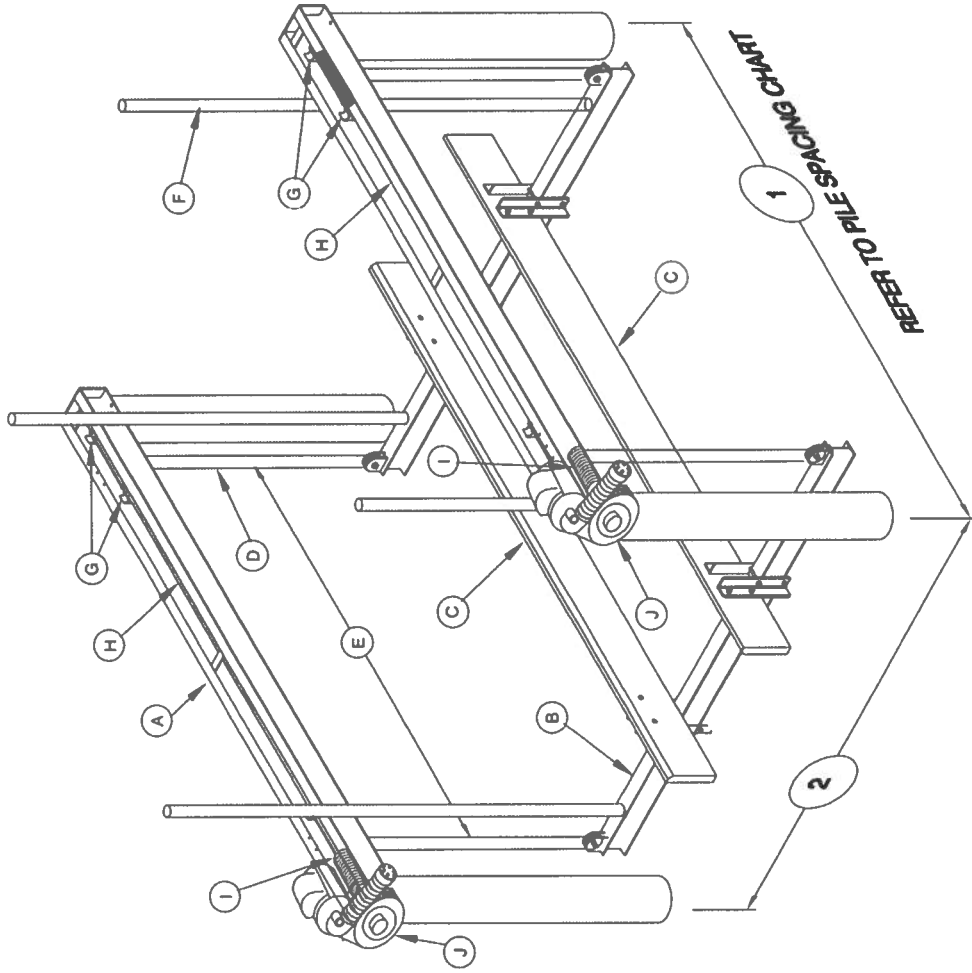
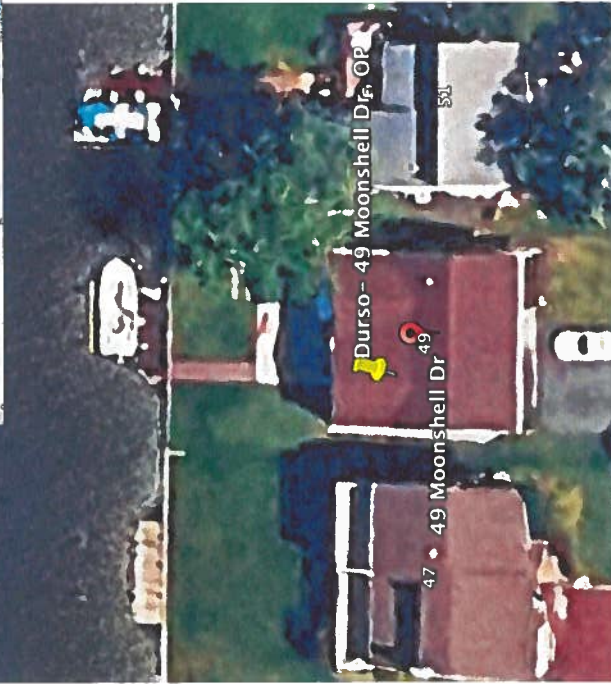

| | | | | | |
|--|---|------------------------------|-------------------------------------|--|--|
| Site: 49 Moonshell Drive, Ocean Pines, MD 21811 | Property Owner: G. Durso | Project ID: 25-243 | Plan: Map/Spec | Notes: -No known SAV -Max Chnl. | Ocean City Boat Lifts (410) 352-5095 oceancitylifts.kayla@aol.com 12010 Industrial Park Rd., Unit 11, Bishopville, MD 21813 |
| Scope of Work: | Remove existing dock & boat lift, Install 5' x 27' pier, Install 4 piling boat lift w/ associate piling | Date: 3/14/2025 | Contractor: OC Boat Lifts | Scale: 1"=5' | |



| | | | | | | |
|----------------|---|-----------------------------|-----------------------|------------------------------|---------------------------------------|---|
| Site: | 49 Moonshell Drive, Ocean Pines, MD 21811 | Property Owner: G. Durso | Project ID: 25-243 | Plan: Site Photo | Notes: -No known SAV -Max Chnl. | Ocean City Boat Lifts (410) 352-5095 oceancitylifts.kayla@aol.com |
| Scope of Work: | Remove existing dock & boat lift, Install 5' x 27' pier, Install 4 piling boat lift w/ associate piling | Scale: 1"=5' | Date: 3/14/2025 | Contractor: OC Boat Lifts | | 12010 Industrial Park Rd., Unit 11, Bishopville, MD 21813 |